

# Concise catalogue "Water-Industry"



*One-channel instruments to measure pH, EC, DO and free chlorine, panel and wall-mounting version.*  
Transmitters - controllers very easy to utilize, the customer does not need user's manual.

***MultiMeter 44**, one multiparametric instrument with configuration for 1, 2 or 3 channels.*  
The most complete instrument with two analogical outputs per channel and relays for limit, alarm and sensor's cleaning.

*Wide range of sensors, from "Low Cost" to "Hi-Tech".*  
Complete assortment of housings for sensors installation in tanks, basins and pipes.





## One-channel instruments for pH, redox, conductivity, DO and free chlorine ..... 4

- pH** pH-meters PH 27, PH 28 and PH 29
- EC** Conductivity meters CM 38 and CM 39
- DO** Oxymeters OXI 49
- Cl<sub>2</sub>** Chlorine meters CL 28

## Multimeters with 1, 2 or 3 channels ..... 6

MultiMeter 44, basic instrument

- pH** pH or redox board
- EC** Electrical conductivity board
- DO** Dissolved oxygen board (amperometric sensor)
- DO** Dissolved oxygen board (optical sensor)
- Cl<sub>2</sub>** Free residual chlorine board

## Sensors..... 8

- For pH or redox
- For conductivity
- For dissolved oxygen (amperometric)
- For dissolved oxygen (optical)
- For free residual chlorine

## Housings for sensor installation ..... 10

- Installation in basin, tanks...
- Pipe installation, with housing
- Pipe installation, without housing

## Portable instruments ..... 11

- pH-meter PH 25
- Conductivity meter CM 35
- Oxymeter OXI 45 P
- Thermometer TM 65
- Multimeter MM 40
- Simulador SI 75

# One-channel instruments for pH, redox, EC, DO and free Cl<sub>2</sub>

## Common features

**Easy to handle.** They enable interactive dialogue in Spanish, English, French or Italian.

**Operating or assisting messages** on the display guide the user.

Simultaneous display of measured parameter and temperature.

Calibration with **automatic standard recognition** and built-in criteria for accepting/rejecting electrodes in poor condition.

**During calibration and programming** the instrument remains in hold.

An access code prevents unauthorised personnel measurement interrupting. Only the authorized personnel have an access to calibration and programming.

**Wall-mounting versions.** Key pad and display hermetically protected by a closing transparent cover. Protection IP 55.



**Panel versions, "P".** Specific for normalized panel mounting, 96x96. Protection IP 54.



## pH pH / mV control

### PH 27 P, transmitter.

- Only panel version.
- Active pH/mV transmitter (4 wires).
- Analogical output, 4...20 mA.

### PH 28 and PH 28 P, controllers.

- Analogical output, 4...20 mA.
- ON/OFF regulation.
- Two relays that can be programmed without distinction as maximum or minimum.

### PH 29 and PH 29 P, controllers.

- Analogical output, 4...20 mA.
- Three relays: limit, alarm and sensor cleaning.
- ON/OFF regulation.
- Proportional regulation.
- Indirect calibration at any pH value.
- *Data logger* with capacity for 200 measurements.
- Possibility to verify manually analogical output and relays activation.
- Selectable temperature sensor, Pt 100 or Pt 1000.

MODELS	PH 27 P	PH 28 PH 28 P	PH 29 PH 29 P
Automatic calibration	•	•	•
Indirect calibration at any value	-	-	•
Programmable analogical output	•	•	•
Regulation On/Off	-	•	•
Proportional regulation	-	-	•
Limit relay	-	2	1 or 2
Cleaning or alarm relay	-	-	1 or 2
Data storage, <i>Data Logger</i>	-	-	•



## EC EC control

All versions have a special measuring circuit. In this way, the cell covers wide range of electrical conductivities.

### CM 38 and CM 38 P, controllers.

- Fixed temperature coefficient, 2%/°C.
- Analogical output, 4...20 mA.
- ON/OFF regulation.
- Two relays, limit and alarm.

### CM 39 and CM 39 P, controllers.

- It allows expressing the conductivity as salinity (NaCl).
- Programmable temperature coefficient between 0 and 5%/°C.
- Reference temperature 20 or 25°C.
- Analogical output 4...20 mA.
- Three relays: limit, alarm or sensor cleaning.
- Regulation On/Off.
- Proportional regulation.
- Indirect calibration at any conductivity value.
- *Data logger* with capacity for 200 measurements.
- Possibility to verify manually analogical output and relays activation.

## DOA DO control

### OXI 49 and OXI 49 P, controllers.

- Calibration in air, 100% saturation.
- The current reading of the electrode during calibration is shown on the display. Very useful for electrode's diagnosis.
- Salinity correction.
- Atmospheric pressure correction.
- Analogical output 4...20 mA.
- Three relays: limit, alarm and sensor cleaning.
- Regulation On/Off.
- *Data logger* with capacity for 200 measurements.
- Possibility to verify manually analogical output and relays activation.
- Amperometric sensor, with membrane.

## Cl<sub>2</sub> Free chlorine control

### CL 28 and CL 28 P, controllers.

- Sensor calibration in one or two points.
- Analogical output 4...20 mA.
- Three relays: limit, alarm and flow alarm.
- Regulation On/Off.
- *Data logger* with capacity for 200 measurements.
- Possibility to verify manually the analogical output and the relays activation.
- Amperometric sensor.

CM 38 CM 38 P	CM 39 CM 39 P	OXI 49 OXI 49 P	CL 28 CL 28 P
•	•	•	-
-	•	-	•
•	•	•	•
•	•	•	•
-	•	-	-
1	1 or 2	1	1
1	1 or 2	2	2
-	•	-	-



## Main features

- One basic instrument to which one, two or three electronics boards can be connected.
- The measurements with all channels are shown simultaneously.
- Security code prevents measurement interruption by unauthorized personnel.
- One single temperature sensor can be used for the temperature compensation in the different channels.
- 4-20 mA outputs programmable between two values from the measuring range.
- RS 232 for data sending to PC.
- Possibility to send data to GSM net (optional).
- PROFIBUS DP communication (optional).
- Software in 4 languages.
- Measurements presentation in standard format or in big format.
- *Data Logger*, 400 data per channel.



## Advantages

- Up to three instruments in one.
- Very easy to use thanks to the user-friendly software.
- Indirect calibration at any pH, redox, conductivity, DO and chlorine value inside the measuring range without sensor dismounting.
- Possibility to verify manually the analogical outputs and the relays activation.
- Display and key pad protected by hermetically closing cover. IP 65 protection.
- Possibility for "in-situ" software updating.
- Panel and field mounting.
- 5 years guarantee for the instrument.
- Technical support directly from the manufacturer.
- Very competitive price.

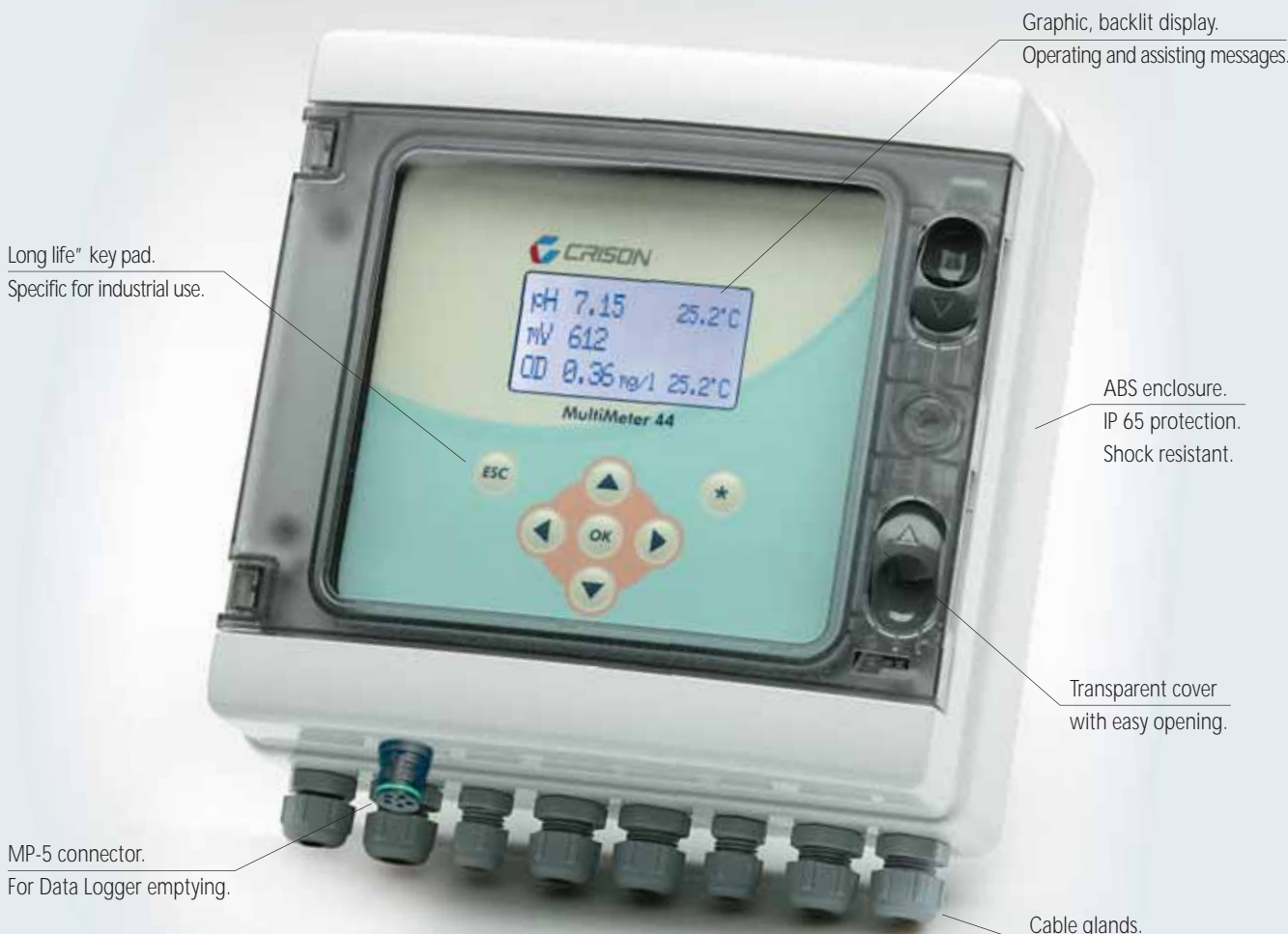

## Maximum security of measurement

The instrument controls continuously the sensors.

If the sensor's signal does not change during the defined period, an alarm is activated. The alarm activates if there is a sharp signal change too. On the graph, two examples of pH measurement are shown.

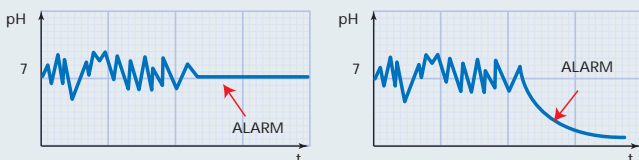

Specifications, basic instrument
Management of 1, 2 or 3 measuring boards
One alarm relay and one sensors cleaning relay.
RS 232 C interface for data sending to PC.
Data sending to GSM net (optional)
PROFIBUS interface (optional)
Programmable <i>Data Logger</i> for 400 measures per channel.
Protection IP 65.
Power supply 230 VCA. Optional: 115 VCA and 24 VCA

The basic instrument, MultiMeter 44 should be complemented with 1, 2 or 3 measure/regulation boards depending on the application's requirement.

The possible measure/regulation boards are:

pH or redox, electrical conductivity, dissolved oxygen (amperometric sensor, with membrane), dissolved oxygen (optical sensor) and free residual chlorine.

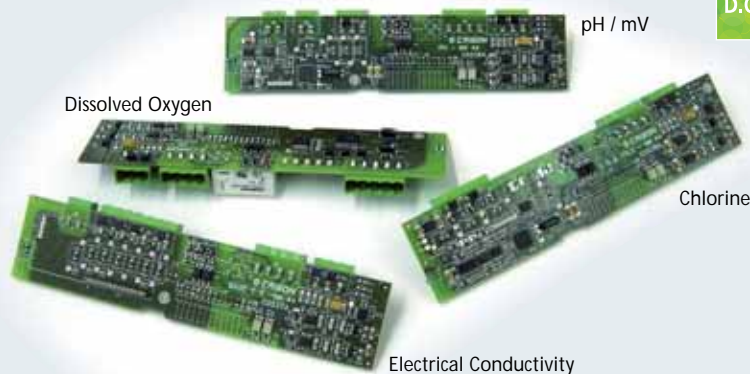

## **pH ORP °C** For pH / redox and °C

Measuring range: pH -2.00 ... 16.00  
mV, ± 2000  
Temperature, -20 ... 150 °C

Calibration possibilities:

- Automatic recognition of pH technical buffers.
- Automatic recognition of redox standard 220 mV.
- Manual calibration at any value of the pH or mV scale.
- Introduction of the calibration data.

Continuous control over the pH sensor (sensor alarm).

## **EC °C** For conductivity and temperature

Measuring range: EC, 0.1 µS/cm ... 500 mS/cm  
Salt, 5 mg/l ... 278 g/l NaCl  
TDS, 0 ... 199 g/l  
Resistivity, 5 Ω ... 100 MΩ  
Temperature, -20 ... 150 °C

Automatic scale change for obtaining of maximum resolution.

Linear temperature coefficient, programmable between 0...5%/C.

Reference temperature, 20 or 25°C.

Calibration possibilities:

- Automatic recognition of CRISON standards.
- Manual calibration at any value at measuring scale.
- Manual introduction of the cell constant.

Continuous control over the sensor (sensor alarm).

## **DOA °C** For dissolved oxygen

**With amperometric sensor (with membrane)**

Measuring range: % saturation, 0 ... 200 %  
Concentration, 0 ... 20 mg/l  
Temperature, 0 ... 50 °C

Calibration possibilities:

- In one point, in air with 100% relative humidity.
- Manual calibration at any value at the measuring range.

## **DOo °C** For dissolved oxygen

**With optical sensor (fluorescence)**

Measuring range: % saturation, 0 ... 250 %  
Concentration, 0 ... 25 mg/l  
Temperature, 0 ... 50 °C

Manual calibration at any value at the measuring range.

## **Cl<sub>2</sub> °C** For free residual chlorine

**With amperometric or redox sensor**

Measuring range: Concentration, 0 ... 5 mg/l  
Temperature, 0 ... 100 °C  
mV, ± 2000 (with redox electrode)

Manual calibration by contrast against DPD1.

Automatic detection of flow drop.

The electronic board can work with amperometric or redox electrode.



### Measuring plates specifications

Parameters	<b>pH ORP °C</b>	<b>EC °C</b>	<b>DOA °C</b>	<b>DOo °C</b>	<b>Cl<sub>2</sub> °C</b>
4-20 mA output for the measured parameter	•	•	•	•	•
4-20 mA output for the temperature	•	•	•	•	•
Two limit relays	•	•	•	•	•
On/Off regulation	•	•	•	•	•
Proportional regulation	•	•	•	•	•
Calibration with standards	•	•	•	-	-
Indirect calibration	•	•	•	•	•

## pH and redox electrodes

Complete range with the best electrodes on the market.

Low maintenance electrodes.

With PG 13.5 thread.

53 00, *Low Cost*.

53 61, *Low Cost*, platinum.

53 33, for clean water.

53 53, for clean water, platinum.

53 03, for low conductivities.

53 62, for low conductivities, platinum.

53 35, for dirty water.

53 55, for dirty water, platinum.

Availability of pressurized and resistant to sterilisation electrodes. Please, ask for details.

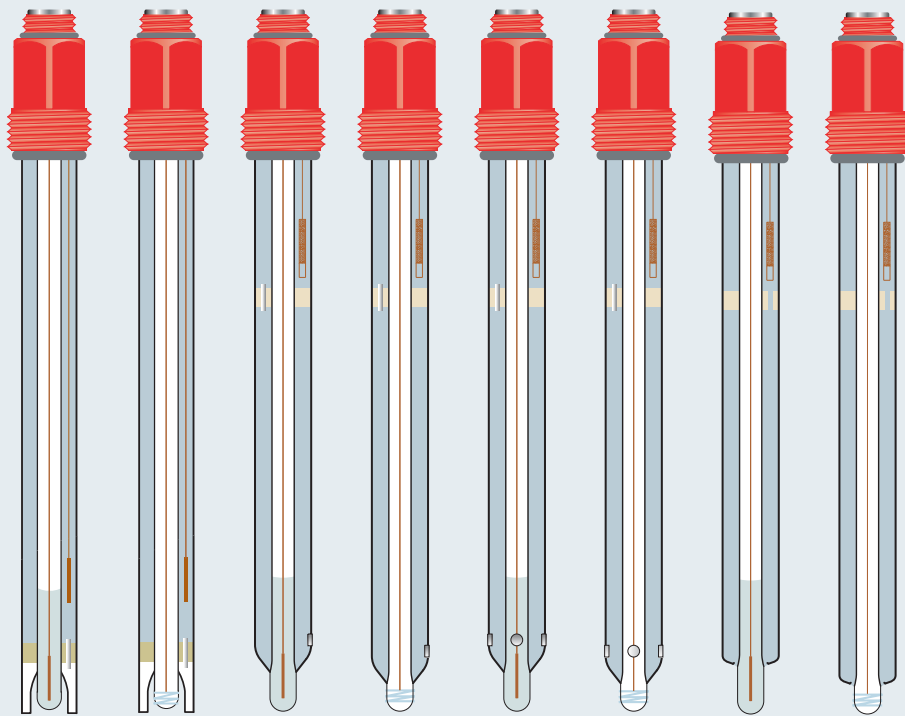

Code	53 00	53 61	53 33	53 53	53 03	53 62	53 35	53 55
Measuring range	pH 0 ... 14	± 2000 mV	pH 0 ... 14	± 2000 mV	pH 0 ... 14	± 2000 mV	pH 2 ... 14	± 2000 mV
Working temperature	0 ... 80 °C		0 ... 80 °C					
Reference element	Ag/AgCl wire		Encapsulated Ag/AgCl					
Diaphragm	1 ceramic		1 ceramic		3 ceramic		Open, anular	
Reference electrolyte	Gel		Gel				Polymer	
Body material	PC (polycarbonate)			Glass				

## Conductivity cells

Different models depending on mounting, materials and measuring interval.

53 88, for basin.

53 98, for pipe and flow-through chamber.

53 90, for pipe, low conductivities.

53 92, for pipe.

53 95, glass and platinum.  $C = 0.1 \text{ cm}^{-1}$ .

53 96, glass and platinum.  $C = 1 \text{ cm}^{-1}$ .

The models 53 95 and 53 96 can also be used with other brands of conductivity meters.



Code	53 88	53 98	53 90	53 92	53 95	53 96
Measuring range ( $\mu\text{S}/\text{cm}$ )	10 ... 80.000	0.5 ... 80.000	0.1 ... 10.000	0.5 ... 80.000	0.1 ... 50.000	1 ... 200.000
Working temperature	0 ... 80 °C		0 ... 100 °C		0 ... 80 °C	
Temperature sensor	Pt 1000		Pt 1000		—	
Thread	PG 13,5		R 1/2"		PG 13,5	
Materials	Titanium		Titanium		Glass / Platinum	
Connector	MP-5		MP-5		S8	

## DO electrode amperometric, with membrane

Code 60 50 (without cable).

Plastic body, VP connector with IP68 providing excellent protection of the connection cable-connector in the most adverse industrial conditions.

Membranes with excellent chemical and mechanical resistance. Easy replacement. Integrated NTC temperature sensor.

Measuring range: 0.3% (0.03 mg/l) up to saturation.

Working temperature: 0 ... 50 °C.

Maximum working pressure: 2 bar.

Body material: PPS (polyphenylene sulphide).

Membrane: PTFE/silicone/PTFE reinforced with steel mesh.

60 50

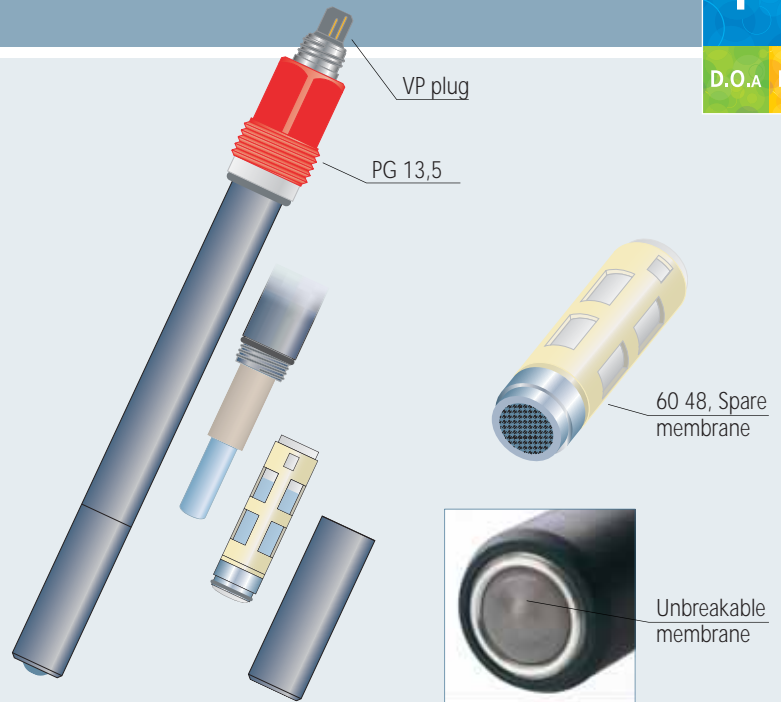

## Optical DO sensor by fluorescence

Code 60 31. including cable with 10 m length.

Optical, solid state sensor based on fluorescence technology. No maintenance required.

Precise measurements of very low DO concentrations.

No need of sample flow.

Sensor does not have to remain moist.

It is not affected by sun light.

Sensor's life, from 7 to 10 years.

Measuring range: 0.00 ... 25.0 mg/l.

Working temperature: 0 ... 60 °C.

Maximum working pressure: 6 bar.

Body material: Epoxy, polyurethane and PVC.

Sensitive zone: immobilized ruthenium compound.

60 31

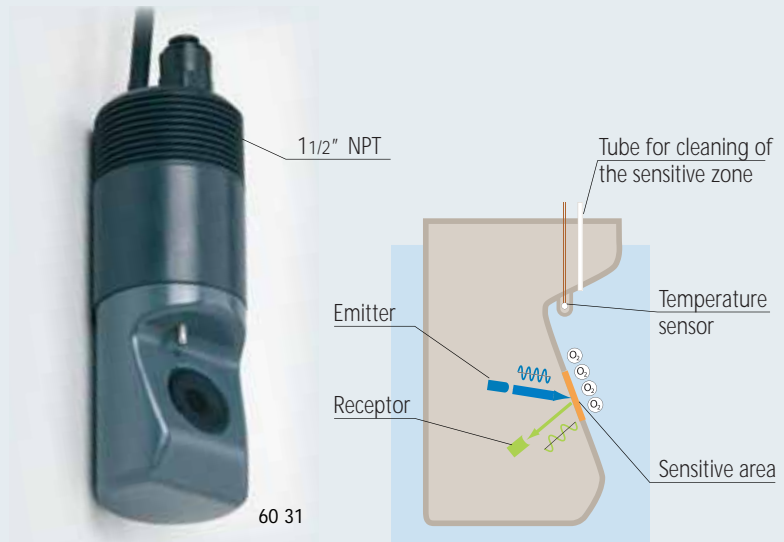

## Free chlorine cell (galvanic cell)

Code 53 59 (without cable).

It is a galvanic cell for free chlorine measurements in water.

Golden electrode with 0.5 mm thickness and large surface.

Solid copper electrode.

Integrated temperature probe Pt 1000.

Its design avoids the usual problem of bubbles in the conventional cells. It is very difficult to be clogged.

Measuring range: 0.00 ... 5.00 mg/l

Working temperature: 5 ... 60 °C

Maximum working pressure: 5 bar.

Chamber material: PVC.

Electrode material: Copper and gold.

53 59

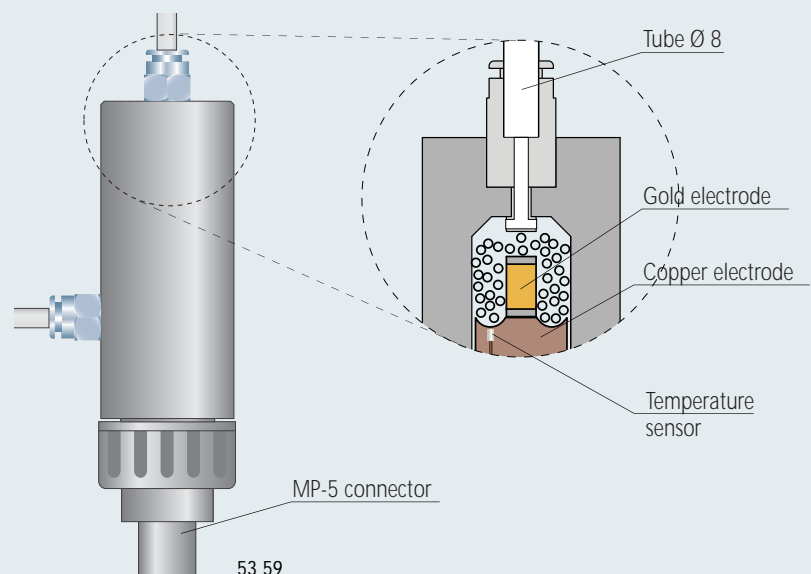

# Housings for sensor installation

The correct installation of a sensor in a process requires a housing. It is intended to:

- Protect the electrode against mechanical impacts.
- Prevent splashing, "flooding" and chemical attack on electrode and cable connectors.
- Ensure that the sensitive part of the electrode is immersed.
- Extend electrode life.
- Facilitate sensor maintenance.

CRISON offers different models depending on the mounting type and application.

## Installation in basins, tanks, deposits...

- 61 01** Immersion housing for 1 sensor.
- 63 01** Housing with automatic cleaning.
- 60 00** "Flotation" housing.
- 77 01** Insertion housing, in PVC.
- 78 01** Insertion housing, in stainless steel.

## Mounting examples

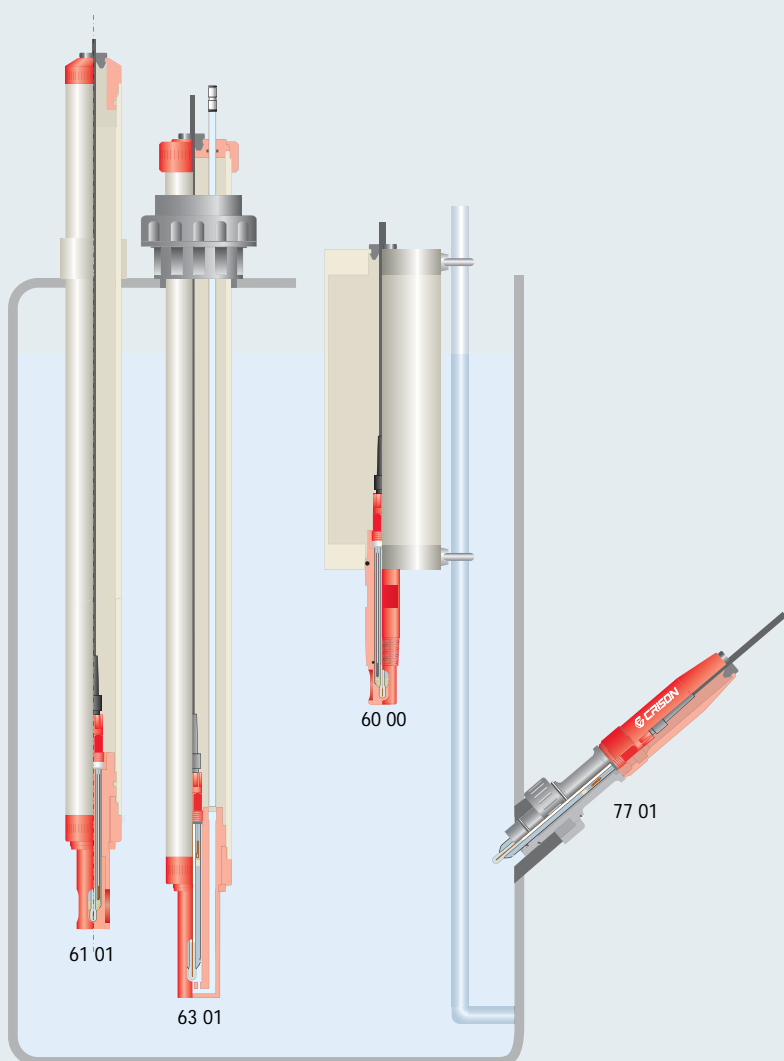

## Pipe installation, with housing.

- 76 01** Insertion housing, in PVC, thread  $\frac{3}{4}$ ".
- 60 03** Flow-through chamber for placing up to 3 sensors.
- 77 01** Insertion housing, in PVC.
- 78 01** Insertion housing, in stainless steel.

## Pipe installation, without housing.

Economic versions:

- 76 00** Electrode adaptor in PVC.
- 61 25** Adaptor for installation of sensor with screw PG13.5 in 3-piece union DN 20.

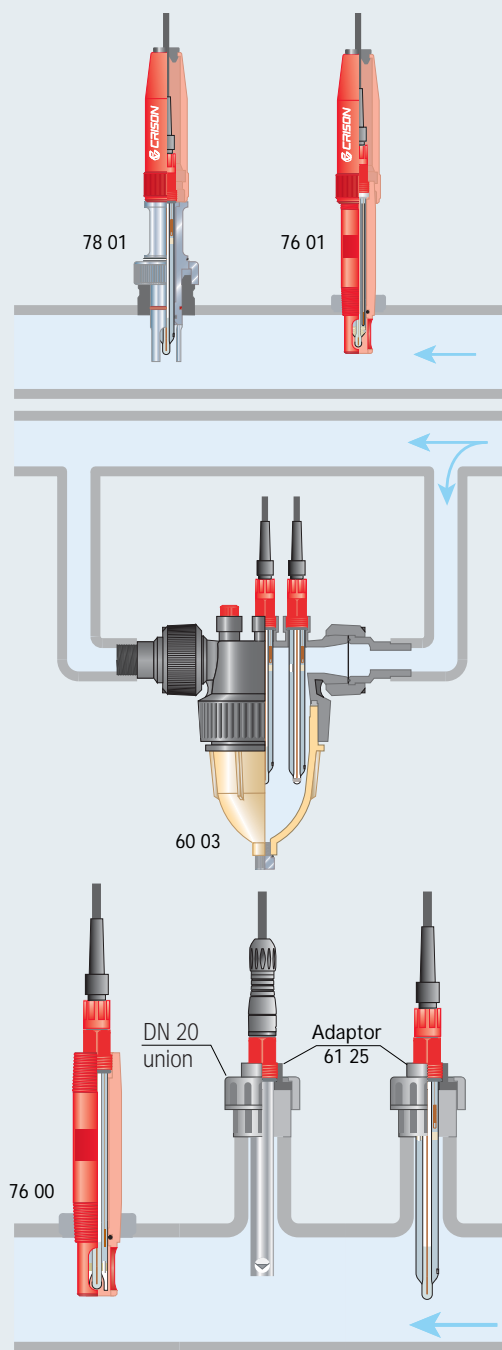

## Functional and very resistant.

Designed to measure in harsh conditions.

**pH °C** pH-meter PH 25

**EC °C** Conductivity meter CM 35

**DO °C** Oxymeter OXI 45 P

**°C** Thermometer TM 65

**pH EC °C** MultiMeter MM 40

pH/mV Simulator SI 75

**i**  
Ask for  
specific leaflet.



**pH °C** PH 25, complete with carry case, buffer solutions and pH electrode. A small portable laboratory. Long-life batteries. Industrial-use keypad. Shock resistant.



**EC °C** CM 35, conductivity meter. With or without carry case. Compatible with different kind of conductivity cells.



**DO °C** OXI 45, oxygen meter. With or without carry case. Uses the best D.O. sensor, with a high resistance membrane.



**pH EC °C** MM 40 multimeter. With or without carry case. Only one sensor for pH, electrical conductivity and °C measurements.

## pH buffers, redox and conductivity standard solutions

